



NÜKTE TRAILER

CATALOGUE DE PRODUITS



SACHEZ QUI EST DERRIÈRE VOUS!

Nükte Trailer, une organisation Nükte Automotive, est l'un des acteurs importants du secteur turc des véhicules utilitaires. Grâce à notre approche de service dynamique et orientée client, nous sommes devenus l'une des marques les plus appréciées, les plus fiables et les plus préférées dans les enquêtes de réputation d'entreprise au sein de l'industrie. La confiance dans notre entreprise est l'indicateur le plus important de notre contribution à l'économie du pays. Fournir le meilleur service à nos clients est devenu pour nous un processus d'apprentissage continu.

Fournir le meilleur service est une question de fierté pour nous.



Ahmet Nükte

NÜKTE OTOMOTİV
Président du conseil
d'administration

PIONNIER DE L'INNOVATION ET DE LA QUALITÉ

Nükte Trailer, en tant qu'entreprise opérant dans le secteur des véhicules lourds, s'est engagée dans une démarche visant à maximiser la satisfaction de ses clients. Nükte Trailer inclut la qualité, la fiabilité et l'innovation parmi ses valeurs fondamentales. Études de R&D dans la production de remorques Nükte Trailer a commencé des études de R&D dans le secteur des remorques en 2020 afin de répondre aux besoins des remorques en fonction des demandes de ses clients. Dans ce processus, elle a déployé des efforts intenses pour développer ses produits, évaluer des prototypes et optimiser sa production et sa chaîne d'approvisionnement.



NÜKTE TRAILER

www.nuktrailer.com 444 6 121

ARKANDA KİM

OLDUGUNU BİL!



PORTE-PLATEFORME SURBAISSÉE À 3 ESSIEUX

APPLICATION TÔLE ET SOUDURE

Tôle haute résistance de qualité S355 ou MC700.
Application de soudage synergique.

INTERVALLES DE MESURES

En fonction de la demande du client, la largeur peut varier de 2550 mm à 4000 mm.
La longueur de la plate-forme peut aller de 5000 mm à 12 000 mm.
La longueur totale peut aller de 10 700 mm à 16 000 mm.

FONCTIONS D'OUVERTURE LATÉRALE

Option d'extension jusqu'à 250 mm de droite et de gauche.

FONCTION DE GARDE AU SOL DE LA REMORQUE

Jusqu'à 775 mm - 1100 mm, selon la demande du client.

KING-PIN

King-Pin de 2" et 3,5" approuvé par la réglementation ECE-R55.
Il peut varier selon les tracteurs 4x2-6x2 ou 6x4.

SPÉCIFICATIONS DES ESSIEUX ET DES PNEUS

Des pneus adaptés aux jantes de taille 17,5 - 19,5 ou 22,5 sont préférables.
Essieux : Essieu à tambour d'une capacité de 12 tonnes.
Système de levage : Un système de levage automatique de l'essieu sensible à la charge est disponible sur l'essieu avant.
Options d'essieu pivotant : Un essieu pivotant peut être ajouté selon la demande du client.

CARACTÉRISTIQUES DE SUSPENSION

Suspension mécanique ou pneumatique, selon la préférence du client.

OPTIONS DE PIED DE RAMPE (ÉCHELLE)

Options de rampes hydrauliques à déplacement latéral, brisées ou monobloc pouvant descendre jusqu'à un angle de chargement allant jusqu'à 9 degrés.
Unité d'alimentation 24 V CC (moteur hydraulique). Pistons hydrauliques spéciaux avec verrous de sécurité qui varient selon les options.
Le pied est recouvert de bois ou de tôle grillagée.

SYSTÈME DE FREINAGE

Système de freinage approuvé par la réglementation ECE-R13.

SYSTÈME ÉLECTRIQUE

Prise 2x7 broches conforme aux normes ISO.
Prise 15 broches conforme à la législation ADR conforme aux normes ISO.
Feux stop arrière 7 fonctions (avec avertisseurs sonores).
2 feux de position de fin de ligne à LED blancs.
Feux de position latéraux ambrés selon la longueur de la plate-forme.
Équipement d'éclairage supplémentaire qui sera nécessaire pendant la route et les travaux.

APPLICATIONS DE PEINTURE

Avant la peinture, un sablage est effectué selon les normes ISO, avec un grade SA2.5.
Après le sablage, un nettoyage chimique est appliqué.
Un traitement zinc-rich ou de métallisation est effectué selon la demande du client.
La peinture est réalisée dans une cabine de peinture avec séchage au four, en utilisant un primaire époxy et de la peinture acrylique.

***Peut être fabriqué selon les dimensions souhaitées.**

ACCESSOIRES

3 armoires (col de chameau).
2 boîtes à outils.
Calage de roue.
Feux rotatifs avant et arrière.
Feu de travail.
Anneaux Roro galvanisés.
Bras d'expansion galvanisés.
Plaque de montage de roue de secours galvanisée
Réflecteurs d'expansion latéraux galvanisés.
2 emplacements pour fixer des armoires à extincteur galvanisées.



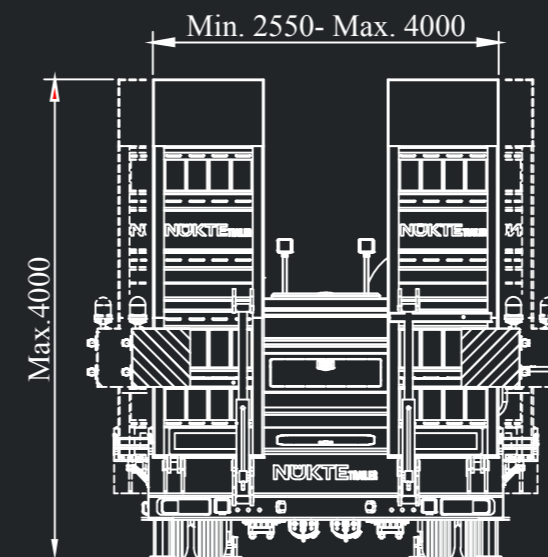
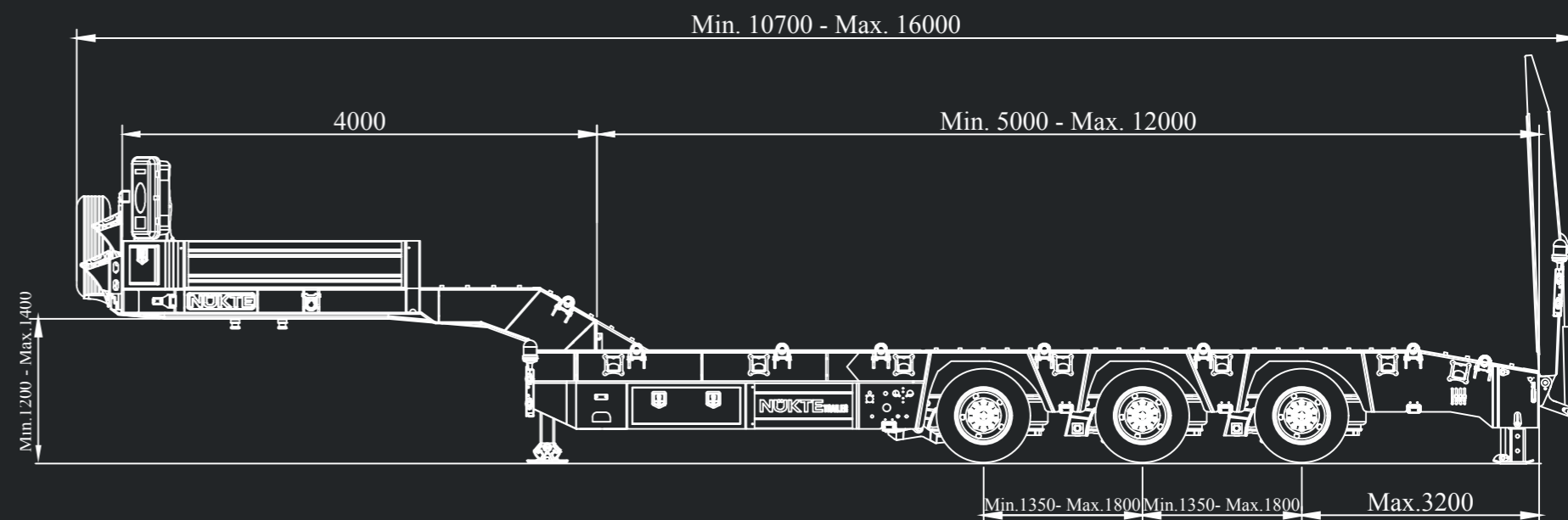

PORTE-PLATEFORME SURBAISSÉE À 3 ESSIEUX

3 AXLES EXTANDABLE LOWBED



APPLICATION TÔLE ET SOUDURE

Tôle haute résistance de qualité S355 ou MC700.
Application de soudage synergique.

INTERVALLES DE MESURES.

La largeur peut varier de 2550 mm à 4000 mm, selon la demande du client.
La longueur de la plate-forme peut aller de 10 700 mm à 35 000 mm.
La taille de l'extension de la plate-forme peut aller de 3 500 mm à 23 000 mm.
La longueur totale peut atteindre jusqu'à 40 400 mm.

FONCTIONS D'OUVERTURE LATÉRALE

Option d'extension jusqu'à 250 mm de droite et de gauche.

FONCTION DE GARDE AU SOL DE LA REMORQUE

Jusqu'à 775 mm - 1100 mm, selon la demande du client.

KING-PIN

King-Pin de 2" et 3,5" approuvé par la réglementation ECE-R55.
Il peut varier selon les tracteurs 4x2-6x2 ou 6x4.

SPÉCIFICATIONS DES ESSIEUX ET DES PNEUS

Des pneus adaptés aux jantes de taille 17,5 - 19,5 ou 22,5 sont préférables.
Essieux : Essieu à tambour d'une capacité de 12 tonnes.
Système de levage : Un système de levage automatique de l'essieu sensible à la charge est disponible sur l'essieu avant.
Options d'essieu pivotant : Un essieu pivotant peut être ajouté selon la demande du client.

CARACTÉRISTIQUES DE SUSPENSION

Suspension mécanique ou pneumatique, selon la préférence du client.

OPTIONS DE PIED DE RAMPE (ÉCHELLE)

Options include hydraulic side-shifting folding ramps or single-piece ramps that descend to an angle of up to 9 degrees.
Powered by a 24 V DC Power Unit [Hydraulic Motor].
Safety-locked hydraulic pistons vary according to options.
Covered with either wooden planks or grid plates on the ladders.

SYSTÈME DE FREINAGE

Système de freinage approuvé par la réglementation ECE-R13.

SYSTÈME ÉLECTRIQUE

Prise 2x7 broches conforme aux normes ISO.
Prise 15 broches conforme à la législation ADR conforme aux normes ISO.
Feux stop arrière 7 fonctions [avec avertisseurs sonores].
2 feux de position de fin de ligne à LED blancs.
Feux de position latéraux ambrés selon la longueur de la plate-forme.
Équipement d'éclairage supplémentaire qui sera nécessaire pendant la route et les travaux.

ACCESSOIRES

3 armoires [col de chameau].
2 boîtes à outils.
Calage de roue.
Feux rotatifs avant et arrière.
Feu de travail.
Anneaux Roro galvanisés.
Bras d'expansion galvanisés.
Plaque de montage de roue de secours galvanisée
Réflecteurs d'expansion latéraux galvanisés.
2 emplacements pour fixer des armoires à extincteur galvanisées.

APPLICATIONS DE PEINTURE

Avant la peinture, un sablage est effectué selon les normes ISO, avec un grade SA2.5.
Après le sablage, un nettoyage chimique est appliqué.
Un traitement zinc-rich ou de métallisation est effectué selon la demande du client.
La peinture est réalisée dans une cabine de peinture avec séchage au four, en utilisant un primaire époxy et de la peinture acrylique.

***Peut être fabriqué selon les dimensions souhaitées.**



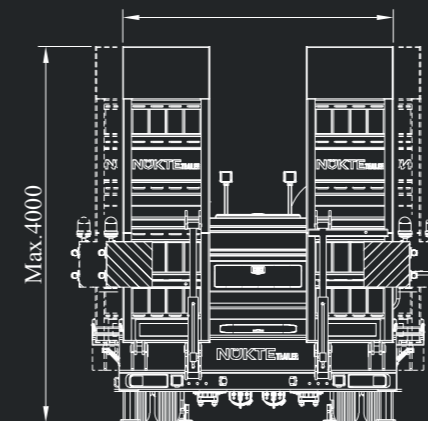
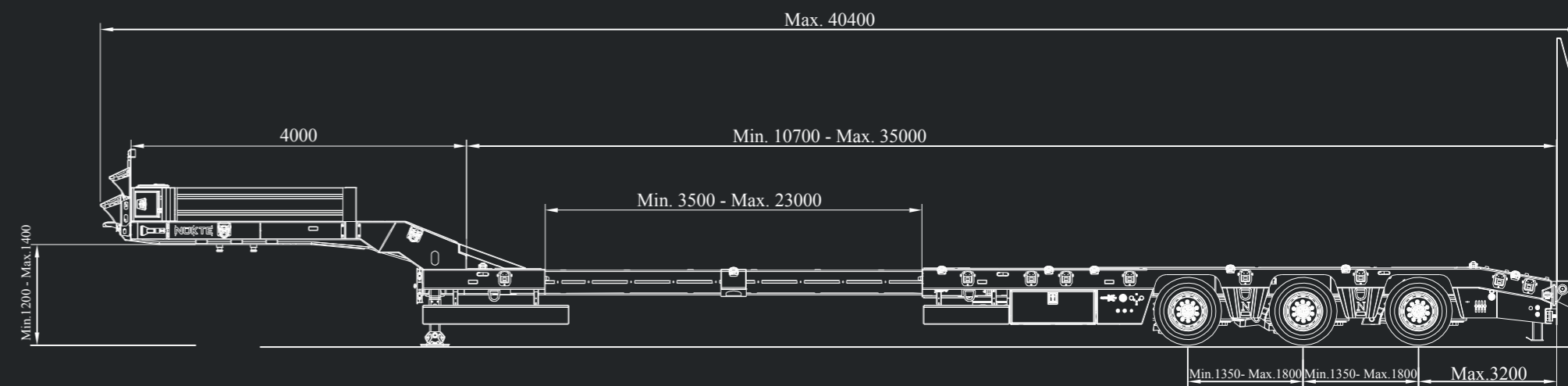

SEMI-REMORQUE EXTENSIBLE À 3 ESSIEUX

PORTE-PLATEFORME SURBAISSÉE À 4 ESSIEUX



***Peut être fabriqué selon les dimensions souhaitées.**

APPLICATION TÔLE ET SOUDURE

Tôle haute résistance de qualité S355 ou MC700.
Application de soudage synergique.

INTERVALLES DE MESURES.

La largeur peut varier de 2550 mm à 4000 mm, selon la demande du client.
La longueur de la plate-forme peut aller de 7 000 mm à 14 000 mm.
La longueur totale peut atteindre jusqu'à 18 000 mm.

CARACTÉRISTIQUES D'EXTENSION LATÉRALE

Possibilité d'extension jusqu'à 250 mm sur les côtés droit et gauche.

CARACTÉRISTIQUE DE GARDE AU SOL DE LA REMORQUE

Elle varie en fonction des exigences du client, allant de 775 mm à 1100 mm.

KING-PIN

Approuvé par la réglementation ECE-R55, disponible en options 2" et 3,5".
Variabilité en fonction des configurations de tracteur 4x2-6x2 ou 6x4.

CARACTÉRISTIQUES DE L'ESSIEU ET DES PNEUS

Les pneus sont choisis en fonction des jantes de taille 17,5 - 19,5 ou 22,5.
Essieux : Essieux à tambour avec une capacité de 12 à 18 tonnes.
Système de levage : Un système de levage automatique de l'essieu avant, sensible à la charge, est disponible.
Options d'essieux pivotants : Un essieu pivotant peut être ajouté selon la demande du client.

CARACTÉRISTIQUES DE LA SUSPENSION

La suspension est disponible en suspension mécanique ou pneumatique, selon le client.

OPTIONS DE PIED DE RAMPE (ÉCHELLE)

Les options comprennent des rampes pliantes à déplacement latéral hydraulique ou des rampes monobloc qui descendent à un angle allant jusqu'à 9 degrés.
Alimenté par un bloc d'alimentation 24 V CC [moteur hydraulique].
Les pistons hydrauliques verrouillés de sécurité varient selon les options.
Recouvert de planches de bois ou de plaques grillagées sur les échelles.

SYSTÈME DE FREINAGE

Système de freinage approuvé par la réglementation ECE-R13.

SYSTÈME ÉLECTRIQUE

Conforme aux normes ISO, équipé de 2 prises à 7 broches.
Prise à 15 broches conforme à la réglementation ADR.
Feux stop arrière à 7 fonctions [avec avertisseur sonore].
2 feux de position latéraux à LED blancs.
Feux de position latéraux ambrés en fonction de la longueur de la plateforme.
Équipement d'éclairage supplémentaire pour l'éclairage routier et opérationnel selon les besoins.

APPLICATIONS DE PEINTURE

Avant la peinture, un sablage est effectué selon les normes ISO, avec un grade SA2.5.
Après le sablage, un nettoyage chimique est appliqué.
Un traitement zinc-rich ou de métallisation est effectué selon la demande du client.
La peinture est réalisée dans une cabine de peinture avec séchage au four, en utilisant un primaire époxy et de la peinture acrylique.

ACCESSOIRES

3 armoires [col de chameau].
2 boîtes à outils.
Calage de roue.
Feux rotatifs avant et arrière.
Feu de travail.
Anneaux Roro galvanisés.
Bras d'expansion galvanisés.
Plaque de montage de roue de secours galvanisée
Réflecteurs d'expansion latéraux galvanisés.
2 emplacements pour fixer des armoires à extincteur galvanisées.



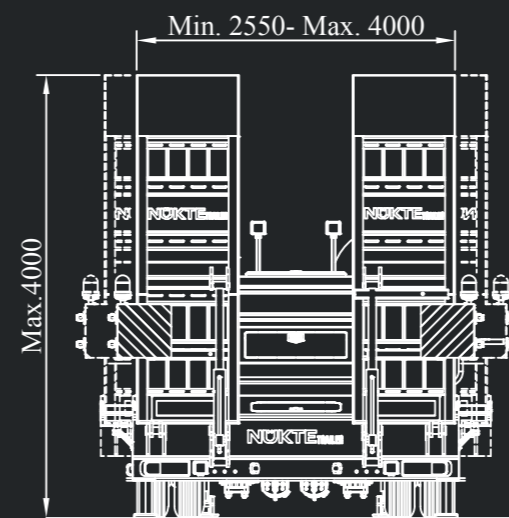
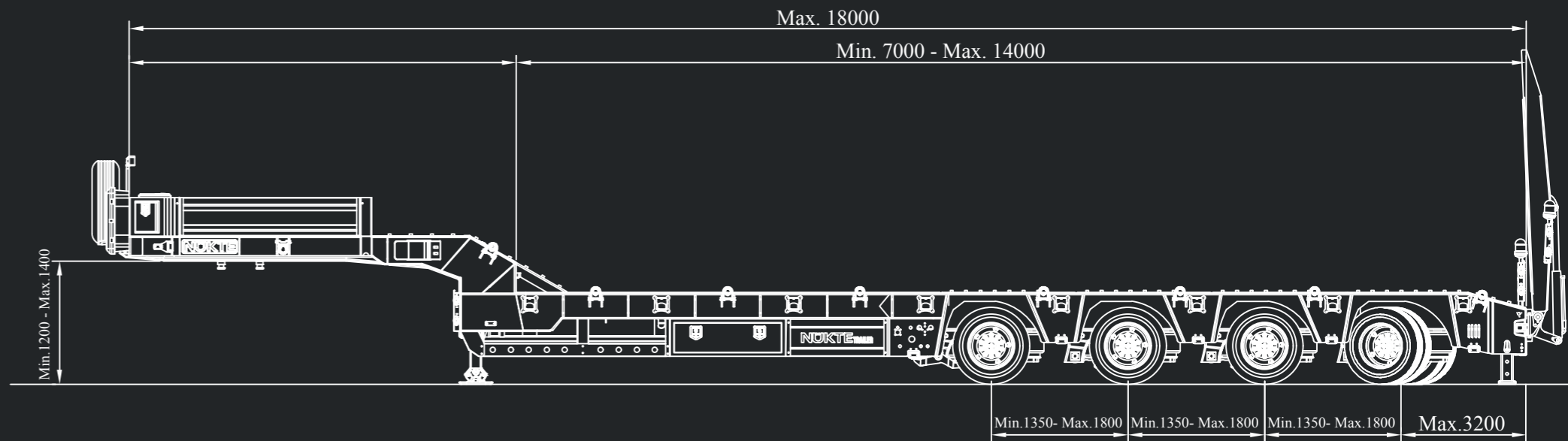

PORTE-PLATEFORME SURBAISSÉE À 3 ESSIEUX

4 AXLE EXTENDABLE LOWBED



SHEET and WELDING APPLICATION

High-Strength Sheet in S355 or MC700 Quality.
Synergistic Welding Application.

MEASURING RANGE

Its width is 2550-4000mm with customer request option.
Platform length is 7.000 - 38.000mm.
Platform Extension Size 3.500mm - 23.000mm
Total length is 40.850mm

SIDE EXTENSION FEATURES

Option to extend up to 250 mm on both the right and left sides.

TRAILER GROUND CLEARANCE FEATURE

Varies based on customer requirements, ranging from 775 mm to 1100 mm.

KING-PIN

Approved by ECE-R55 Regulation, available in 2" and 3.5" options.
Variability depending on 4x2-6x2 or 6x4 tractor configurations.

AXLE and TIRE SPECIFICATIONS

Suitable tire for the jant 17,5-19,5 or 22,5 size
Axles: 12-18 ton capacity drum axle
Lifting system: There is a load-sensitive automatic Axle Lifting System on the Front Axle.
Steering Axle Options: The steering axle can be added with the customer request.

SUSPENSION FEATURES

The suspension is available in either mechanical or air suspension, depending on customer

LADDER OPTIONS

Options include hydraulic side-shifting folding ramps or single-piece ramps that descend to an angle of up to 9 degrees.
Powered by a 24 V DC Power Unit [Hydraulic Motor].
Safety-locked hydraulic pistons vary according to options.
Covered with either wooden planks or grid plates on the ladders.

BRAKE SYSTEM

Brake system approved by ECE-R13 regulation.

ELECTRICAL SYSTEM

Compliant with ISO standards, featuring 2x7-pin sockets. 15-pin socket in compliance with ADR regulations.
Rear stop lights with 7 functions [with horn].
2 white LED side marker lights.
Amber side marker lights based on the platform's length.
Additional lighting equipment for road and operational illumination as needed.

ACCESSORIES

3 Boxes [on the Goosneck].
2 Toolboxes.
Wheel Chock.
Front and Rear Rotating Lights.
Working Light.
Galvanized Roro Rings.
Galvanized Expansion Arms.
Galvanized Spare Tire Mounting Plate
Galvanized Side Expansion Reflectors.
2 qty Fire Cabinet connection part

PAINT APPLICATIONS

Sandblasting process in SA2.5 degree confirmed to ISO Standards is done before painting.
Chemical cleaning are done after sandblasting process.
Zinc-Rich or Metallising process are done by customer request.
It is done with epoxy primer and acrylic paint in paint cabin with oven.

*Measureings can be changed.



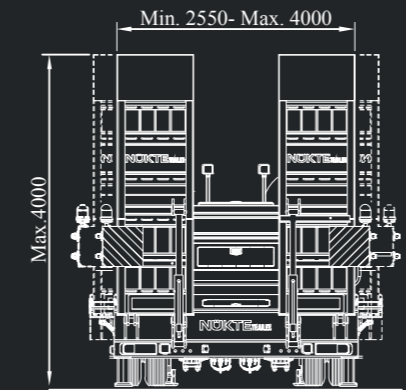
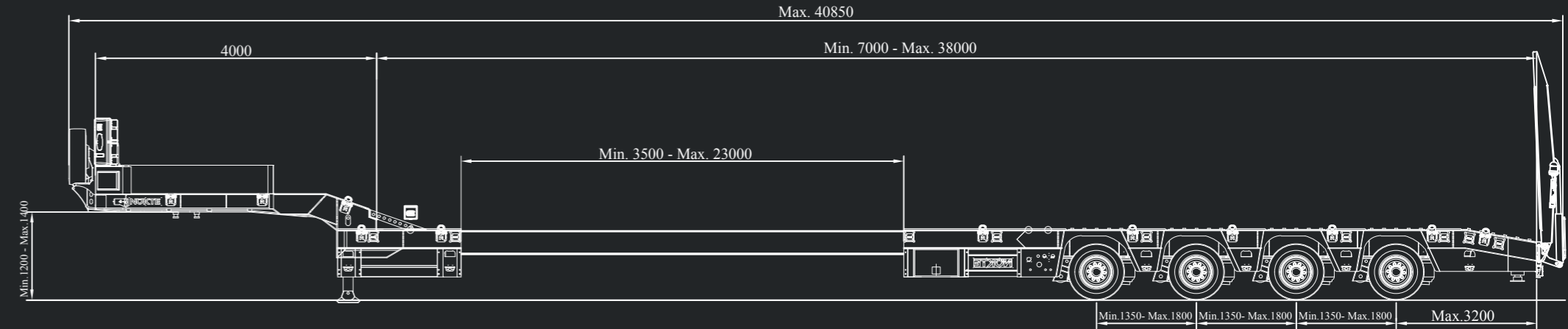

4 AXLES
EXTENDABLE
LOWBED

5 AXLES LOWBED



SHEET and WELDING APPLICATION

High-Strength Sheet in S355 or MC700 Quality.
Synergistic Welding Application.

DIMENSIONAL RANGES

Its width is 2550-4000mm with customer request option.
Platform length is 7.000-16.000mm.
Total length is up to 20.000mm.

SIDE EXTENSION FEATURES

Option to extend up to 250 mm on both the right and left sides.

TRAILER GROUND CLEARANCE FEATURE

Varies based on customer requirements, ranging from 880 mm to 1100 mm.

KING-PIN

Approved by ECE-R55 Regulation, available in 2" and 3.5" options.
Variability depending on 4x2-6x2 or 6x4 tractor configurations.

AXLE and TIRE SPECIFICATIONS

Suitable tire for the jant 17,5-19,5 or 22,5 size
Axles: 12-18 ton capacity drum axle
Lifting system: There is a load-sensitive automatic Axle Lifting System on the Front Axle.
Steering Axle Options: The steering axle can be added with the customer request.

SUSPENSION FEATURES

The suspension is available in either mechanical or air suspension, depending on customer

LADDER OPTIONS

Options include hydraulic side-shifting folding ramps or single-piece ramps that descend to an angle of up to 9 degrees.
Powered by a 24 V DC Power Unit [Hydraulic Motor].
Safety-locked hydraulic pistons vary according to options.
Covered with either wooden planks or grid plates on the ladders.

BRAKE SYSTEM

Brake system approved by ECE-R13 regulation.

ELECTRICAL SYSTEM

Compliant with ISO standards, featuring 2x7-pin sockets. 15-pin socket in compliance with ADR regulations.
Rear stop lights with 7 functions [with horn].
2 white LED side marker lights.
Amber side marker lights based on the platform's length.
Additional lighting equipment for road and operational illumination as needed.

ACCESSORIES

3 Boxes [on the Goosneck].
2 Toolboxes.
Wheel Chock.
Front and Rear Rotating Lights.
Working Light.
Galvanized Roro Rings.
Galvanized Expansion Arms.
Galvanized Spare Tire Mounting Plate
Galvanized Side Expansion Reflectors.
2 qty Fire Cabinet connection part

PAINT APPLICATIONS

Sandblasting process in SA2.5 degree confirmed to ISO Standards is done before painting.
Chemical cleaning are done after sandblasting process.
Zinc-Rich or Metallising process are done by customer request.
It is done with epoxy primer and acrylic paint in paint cabin with oven.

***Measureings can be changed.**



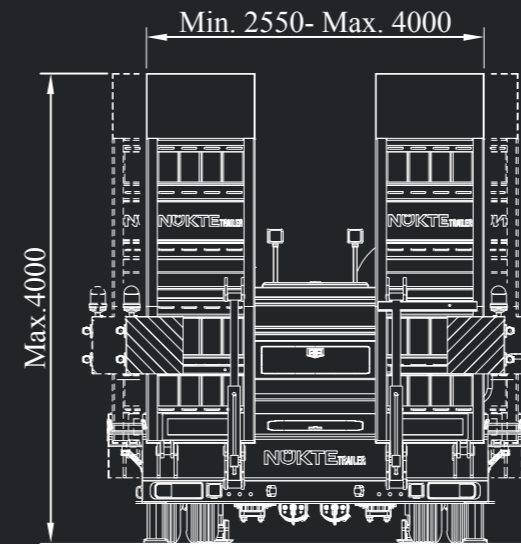
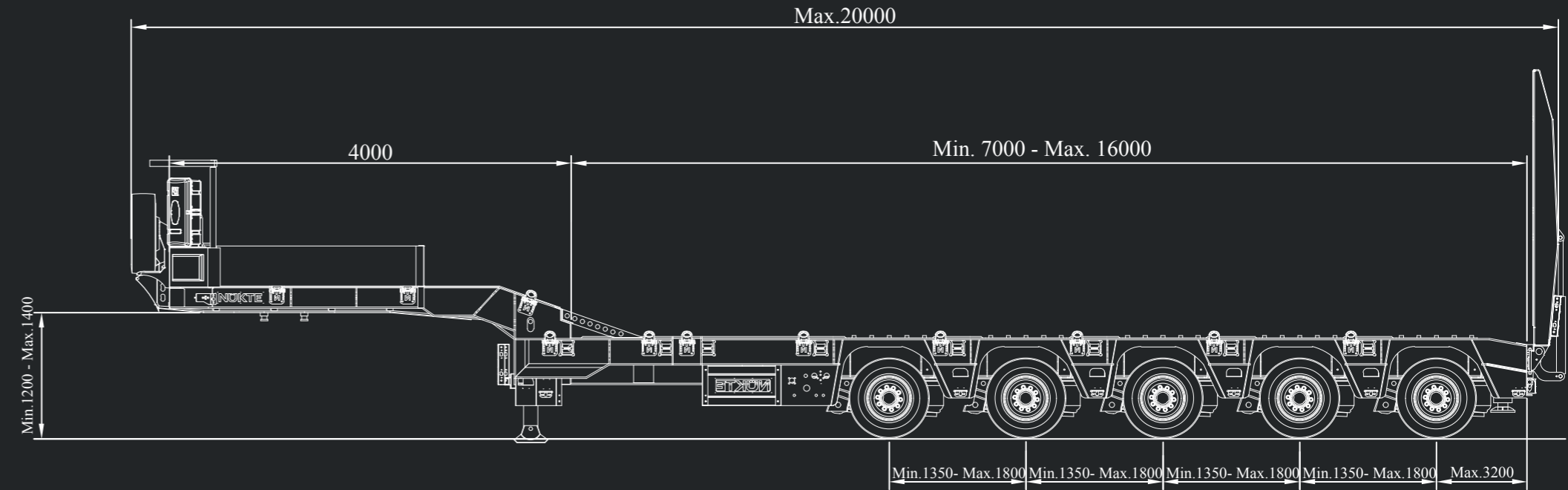

5 AXLES LOWBED

5 AXLES EXTENDABLE LOWBED



EXTENDABLE LOWBED

SHEET and WELDING APPLICATION

High-Strength Sheet in S355 or MC700 Quality.
Synergistic Welding Application.

DIMENSIONAL RANGES

Its width is 2550-4000mm with customer request option.
Platform length is 7.000mm-38.000mm.
Platform extension size 3.500mm-23.000mm
Total length is 42.650mm

SIDE EXTENSION FEATURES

Option to extend up to 250 mm on both the right and left sides.

TRAILER GROUND CLEARANCE FEATURE

Varies based on customer requirements, ranging from 775 mm to 1100 mm.

KING-PIN

Approved by ECE-R55 Regulation, available in 2" and 3.5" options.
Variability depending on 4x2-6x2 or 6x4 tractor configurations.

AXLE and TIRE SPECIFICATIONS

Suitable tire for the jant 17,5-19,5 or 22,5 size
Axles: 12-18 ton capacity drum axle
Lifting system: There is a load-sensitive automatic Axle Lifting System on the Front Axle.
Steering Axle Options: The steering axle can be added with the customer request.

SUSPENSION FEATURES

The suspension is available in either mechanical or air suspension, depending on customer

LADDER OPTIONS

Options include hydraulic side-shifting folding ramps or single-piece ramps that descend to an angle of up to 9 degrees.
Powered by a 24 V DC Power Unit (Hydraulic Motor).
Safety-locked hydraulic pistons vary according to options.
Covered with either wooden planks or grid plates on the ladders.

BRAKE SYSTEM

Brake system approved by ECE-R13 regulation.

ELECTRICAL SYSTEM

Compliant with ISO standards, featuring 2x7-pin sockets.
15-pin socket in compliance with ADR regulations.
Rear stop lights with 7 functions (with horn).
2 white LED side marker lights.
Amber side marker lights based on the platform's length.
Additional lighting equipment for road and operational illumination as needed.

ACCESSORIES

3 Boxes (on the Goosneck).
2 Toolboxes.
Wheel Chock.
Front and Rear Rotating Lights.
Working Light.
Galvanized Roro Rings.
Galvanized Expansion Arms.
Galvanized Spare Tire Mounting Plate
Galvanized Side Expansion Reflectors.
2 qty Fire Cabinet connection part

PAINT APPLICATIONS

Sandblasting process in SA2.5 degree confirmed to ISO Standards is done before painting.
Chemical cleaning are done after sandblasting process.
Zinc-Rich or Metallising process are done by customer request.
It is done with epoxy primer and acrylic paint in paint cabin with oven.

***Measureings can be changed.**



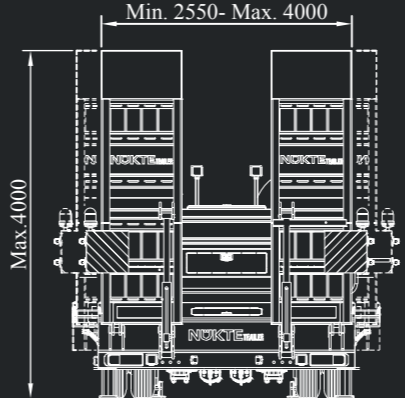
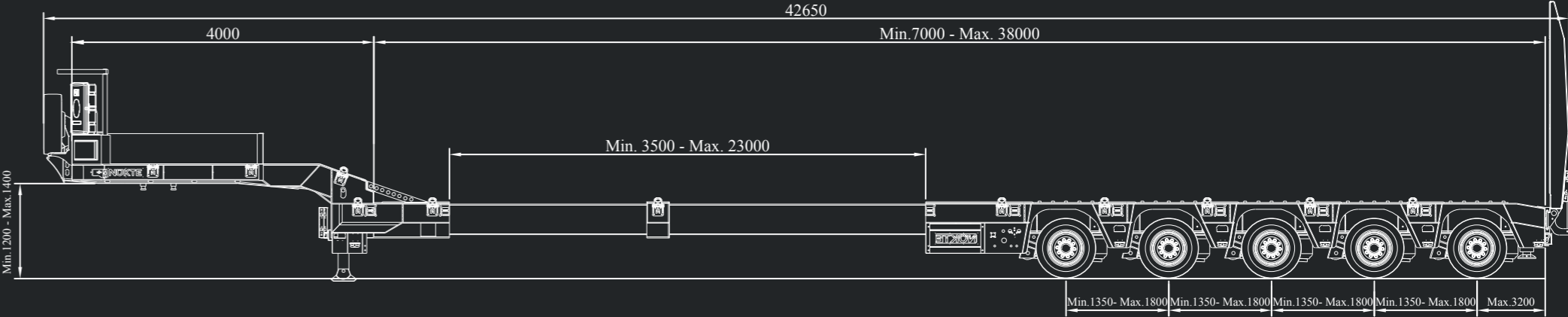

5 AXLES EXTENDABLE LOWBED

4 AXLES TANDEM LOWBED SEMI-TRAILER



SHEET and WELDING APPLICATION

High-Strength Sheet in S355 or MC700 Quality.
Synergistic Welding Application.

MEASURING RANGE

Its width can be 2550mm-4000mm
Its platform length is up to 14.000mm
Its total length is up to 18.000mm.

TRAILER GROUND CLEARANCE FEATURE

Varies based on customer requirements, ranging from 950 mm to 1100 mm.

KING-PIN

The King Pin is 3.5" confirmed by Ece-R55 regulation.
It is 6x2 or 6x4, it is changeable by trucks.

AXLE and TIRE SPECIFICATIONS

Suitable tire for the jant 19,5 or 22,5 size is preferred.
Axles: 4-18 ton capacity drum axle by request.

SUSPENSION FEATURES

It has mechanic suspension.

BRAKE SYSTEM

Options include hydraulic side-shifting folding ramps or single-piece ramps that descend to an angle of up to 9 degrees.
Powered by a 24 V DC Power Unit [Hydraulic Motor].
Safety-locked hydraulic pistons vary according to options.
Covered with either wooden planks or grid plates on the ladders.

BRAKE SYSTEM

Brake system approved by ECE-R13 regulation.

ELEKTRİK SİSTEMİ

Compliant with ISO standards, featuring 2x7-pin sockets.
15-pin socket in compliance with ADR regulations.
Rear stop lights with 7 functions [with horn].
2 white LED side marker lights.
Amber side marker lights based on the platform's length.
Additional lighting equipment for road and operational illumination as needed.

ACCESSORIES

3 Boxes (on the Goosneck).
2 Toolboxes.
Wheel Chock.
Front and Rear Rotating Lights.
Working Light.
Galvanized Roro Rings.
Galvanized Expansion Arms.
Galvanized Spare Tire Mounting Plate
Galvanized Side Expansion Reflectors.
2 qty Fire Cabinet connection part

PAINT APPLICATIONS

Sandblasting process in SA2.5 degree confirmed to ISO Standards is done before painting.
Chemical cleaning are done after sandblasting process.
Zinc-Rich or Metallising process are done by customer request.
It is done with epoxy primer and acrylic paint in paint cabin with oven.

***Measurements can be changed.**



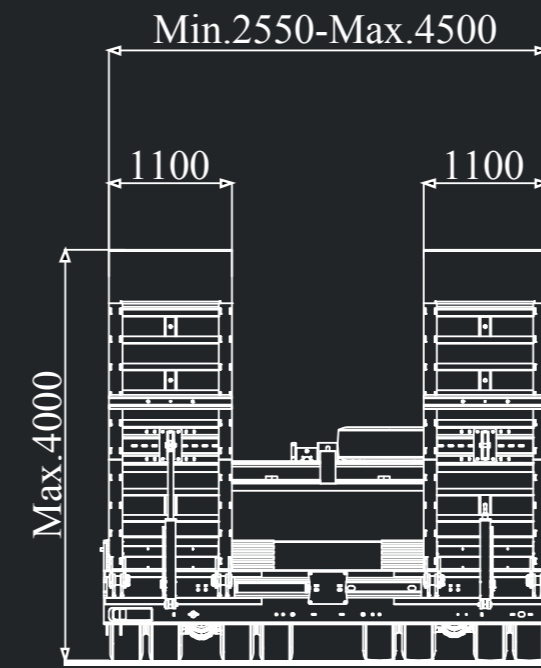
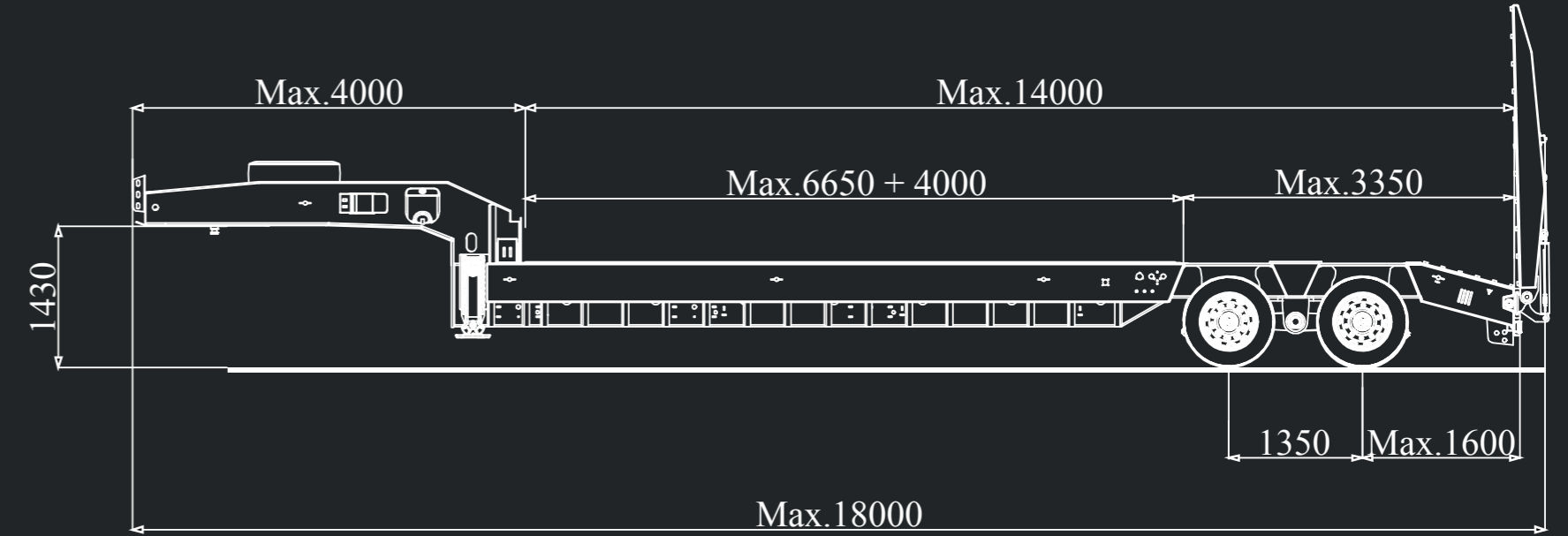

16'LI SERME
DİNGİLLİ
LOWBED

CONTAINER CARRIER



*Measurements can be changed.

SHEET and WELDING APPLICATION

High-Strength Sheet in S355 or MC700 Quality.
Synergistic Welding Application.

DIMENSIONAL RANGES

Its width is 2550-4000mm with customer request option.
Platform length is up to 8.900-13.600mm.
Platform extension size is up to 3400mm
Total length is up to 14.000mm.

SIDE EXTENSION FEATURES

Option to extend up to 250 mm on both the right and left sides.

TRAILER GROUND CLEARANCE FEATURE

Varies based on customer requirements, ranging from 775 mm to 1100 mm.

KING-PIN

Approved by ECE-R55 Regulation, available in 2" and 3.5" options.
Variability depending on 4x2-6x2 or 6x4 tractor configurations.

AXLE and TIRE SPECIFICATIONS

Suitable tire for the jant 17,5-19,5 or 22,5 size
Axles: 12-18 ton capacity drum axle
Lifting system: There is a load-sensitive automatic Axle Lifting System on the Front Axle.
Steering Axle Options: The steering axle can be added with the customer request.

SUSPENSION FEATURES

The suspension is available in either mechanical or air suspension, depending on customer

CONTAINER LOCK SYSTEM

The Container Locks are 2 x 20 ft, 1 x 30 ft, 1 x 40 ft ve 1 x 45 ft container confirmed by ADR document, swap body and high cube container.

BRAKE SYSTEM

Brake system approved by ECE-R13 regulation.

ELECTRICAL SYSTEM

Compliant with ISO standards, featuring 2x7-pin sockets.
15-pin socket in compliance with ADR regulations.
Rear stop lights with 7 functions [with horn].
2 white LED side marker lights.
Amber side marker lights based on the platform's length.
Additional lighting equipment for road and operational illumination as needed.

ACCESSORIES

2 QTY Tool Box
Wheel Chock
Worklamp available for request
1 QTY Fire Cabinet

PAINT APPLICATIONS

Sandblasting process in SA2.5 degree confirmed to ISO Standards is done before painting.
Chemical cleaning are done after sandblasting process.
Zinc-Rich or Metallising process are done by customer request.
It is done with epoxy primer and acrylic paint in paint cabin with oven.



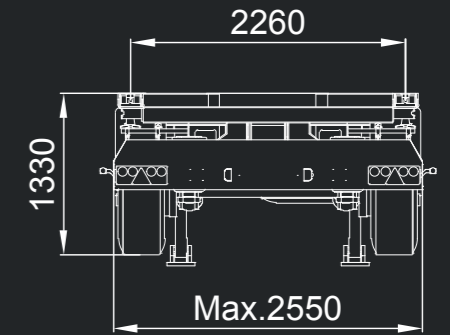
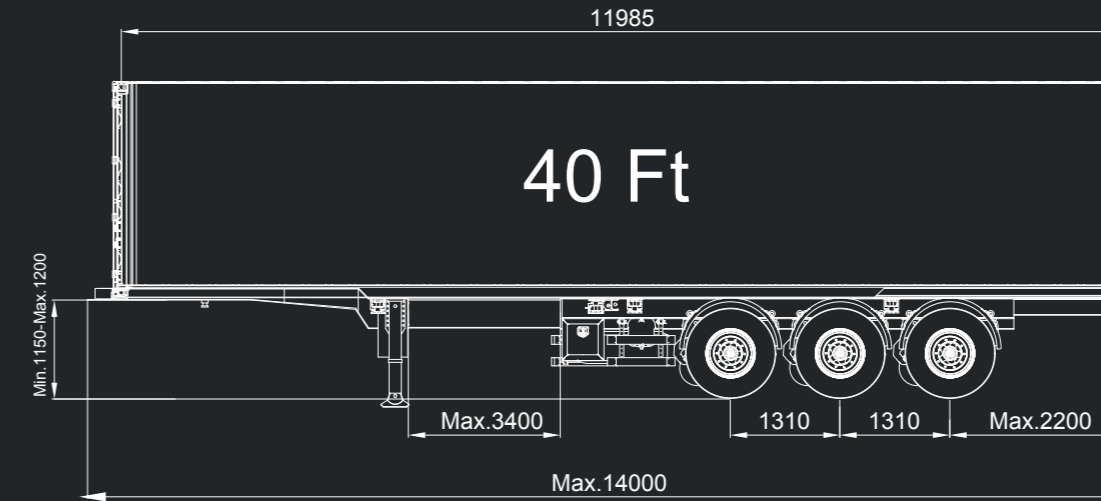
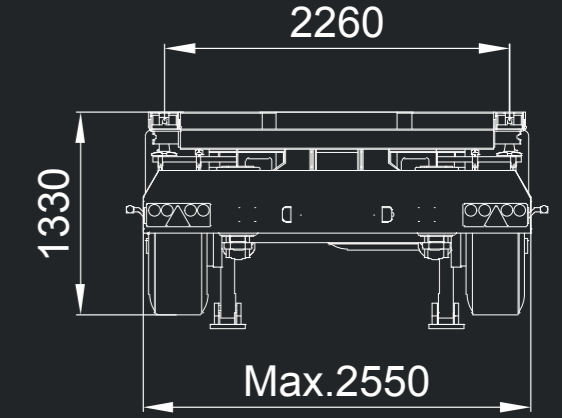
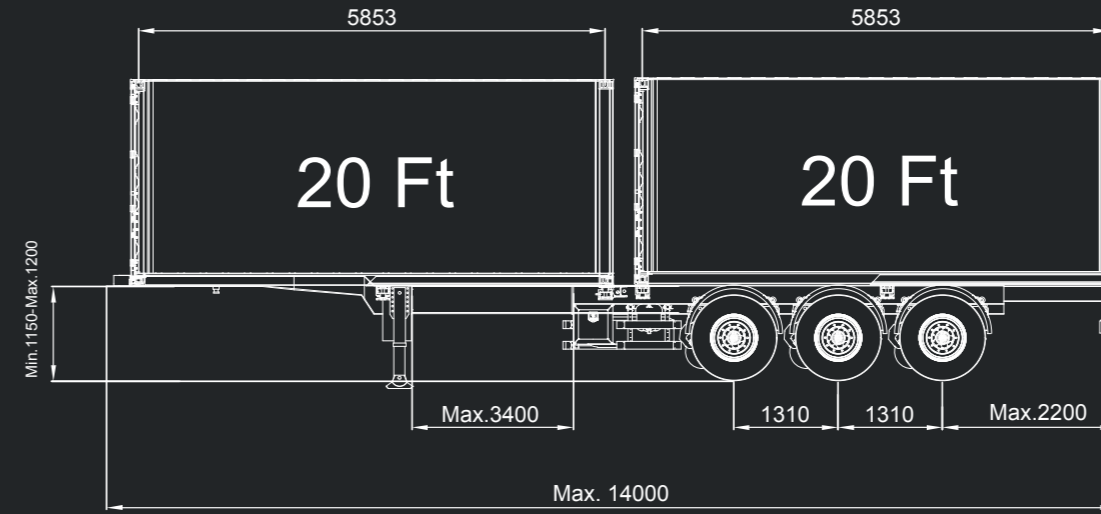

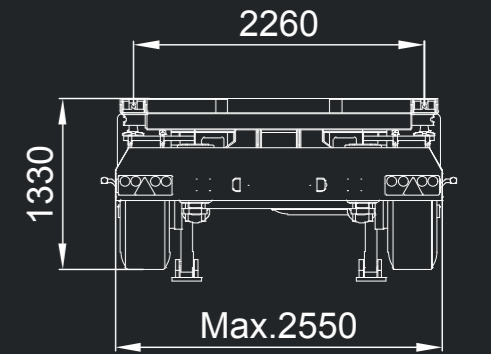
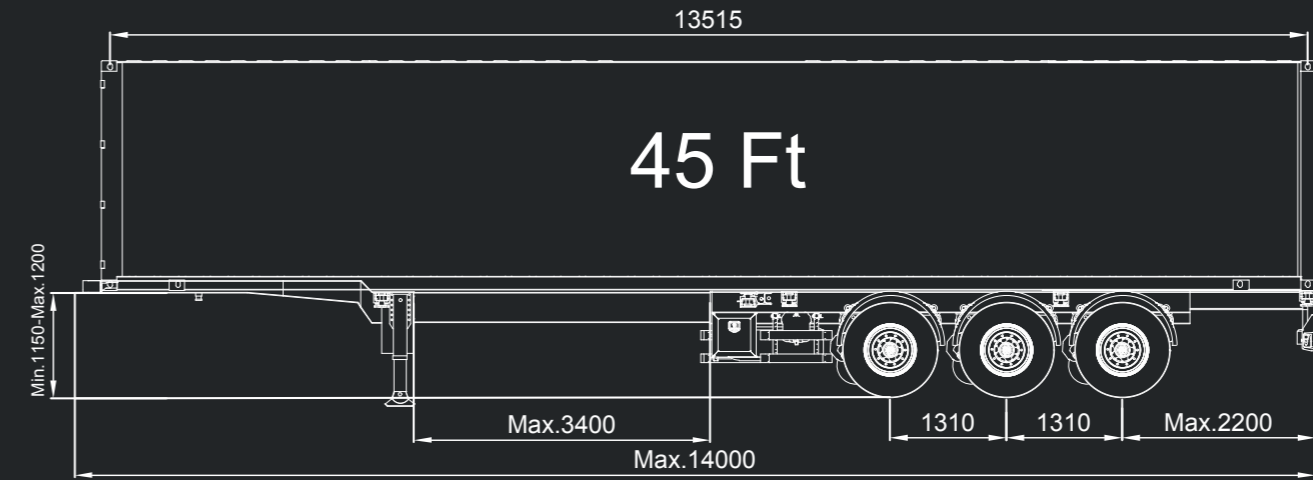
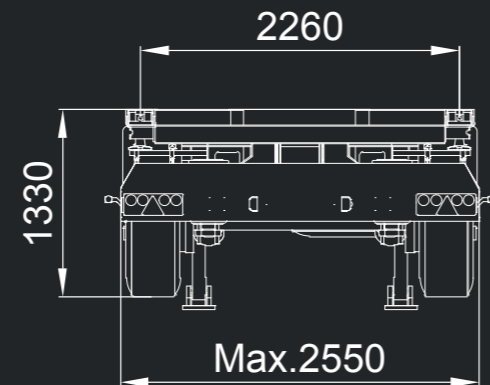
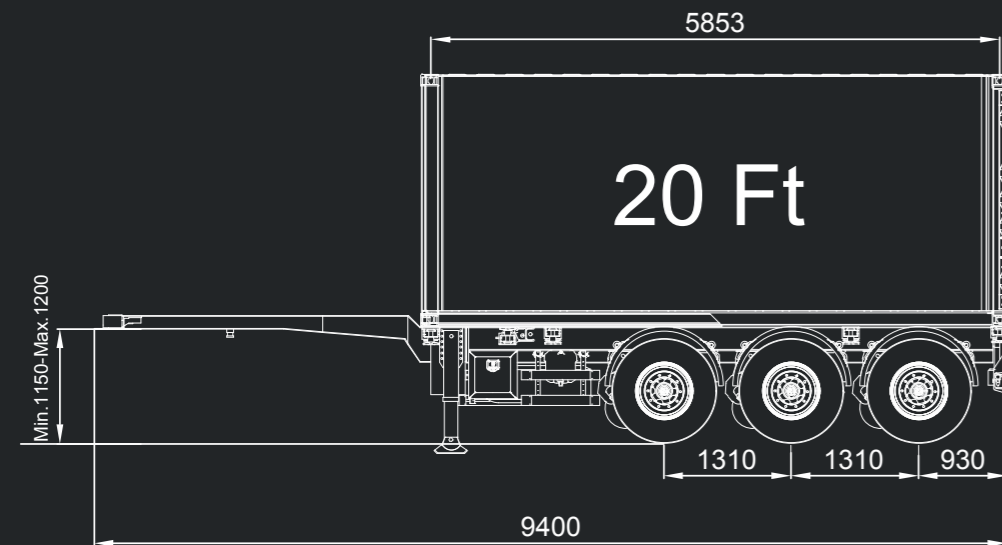
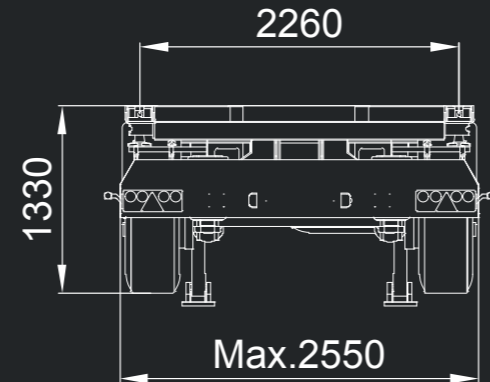
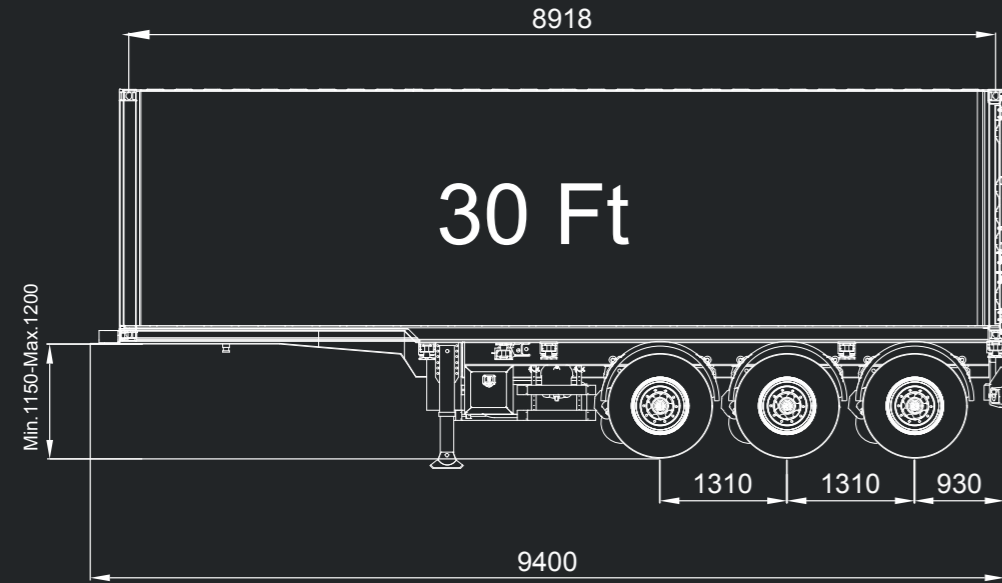

HALF PIPE TIPPING TRAILER

BRAKE SYSTEM: Dual-circuit brake system compliant with ECE R13 regulation. WABCO RSS system with 2S/2M electronic anti-lock braking system. Emergency stop and ramp valve.

TIPPER LIFTING: Front telescopic cylinder, minimum 45° lifting angle, and cold-drawn, high-strength steel cylinder resistant to pressure at this angle.

ELECTRICAL SYSTEM: 7 x 24-volt lighting system compliant with ECE R48 regulation.

AXLE SET: The Axles 9 ton-12 ton can be preferred.

AXLE LIFTING: There is automatic lifting system sensible to load on the front axle.

TIRE/RIM: 6+1 tires and rims, size 385/65 R 22.5.

PUMP: Dual rotary gear pump with a capacity of 35-90 min./lt.

HOSES: R2 steel hoses resistant to a working pressure of 250 bar.

LANDING GEAR: Double-stage telescopic legs and gearboxes with a dynamic load capacity of 24 tons.

SIDE PROTECTION/GUARD: Fixed or foldable type compliant with ECE R73 regulation.

MUDGUARD: Full FRP mud protection on the wheel

PAINT: Sandblasting process in SA2.5 degree confirmed to ISO Standards is done before painting.

Chemical cleaning are done after sandblasting process.

It is done with epoxy primer and acrylic paint in paint cabin with oven.

Zinc-Rich or Metallising process are done by customer request.

ACCESSORIES: Toolbox, water tank, tire bumper, fire extinguisher cabinet, necessary indicator signs, and optional accessories.



***Its M3 is available for customer request.**



VOLUME

Depending on customer preference, in the range of 18-32 m3.

BUFFER

Flexible buffer designed according to ECE R58 regulation. Optionally, a foldable buffer with pneumatic system.

OIL TANK

Specially designed, gasketed, and filtered oil tank.

FRONT PANEL - REAR DOOR

450 Brinell or 500 TUF hardness wear sheet/plate

CHASSIS

Imported S700MC or domestically reinforced S355JR chassis.

POOL MATERIAL

450 Brinell veya 500 TUF Sertliğinde HARDOX Sac Malzemeden

KING PIN

2-inch detachable flanged towing pin according to ECE R55 regulation.

REAR PALLET

For asphalt carriers, wear plate/covering with a hardness of 450 HB.

GROUND / SIDE WALLS

The imported wear sheet/plate with 5/4mm thickness, 450 Brinell or 500 TUF hardness.

TENT SYSTEM

It can be manufactured as hydraulics system, sliding system or automatic tent system.

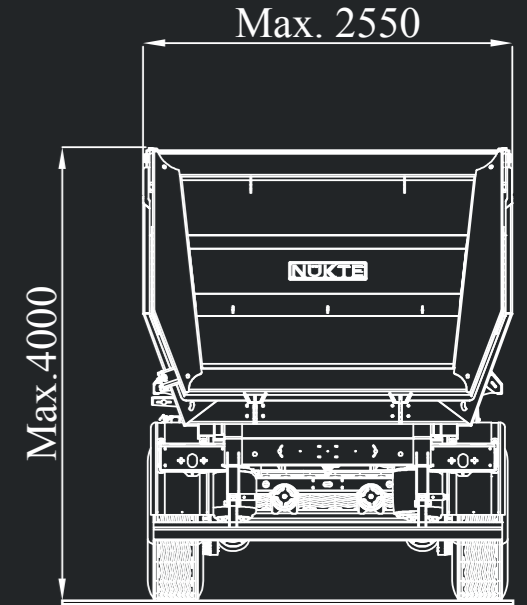
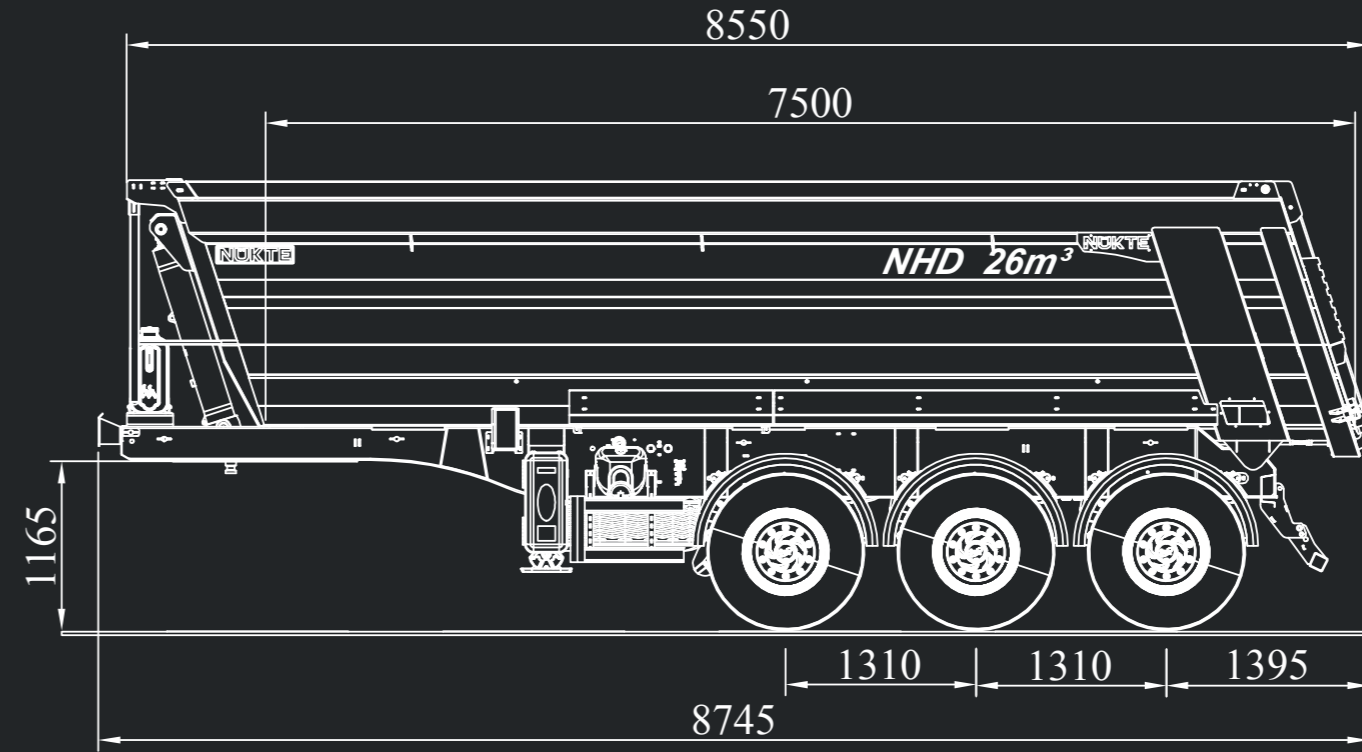

HALF PIPE TIPPING TRAILER

AKORDİYON TRAILER

BRAKE SYSTEM: Dual-circuit brake system compliant with ECE R13 regulation. WABCO RSS system with 2S/2M electronic anti-lock braking system. Emergency stop and ramp valve.

TIPPER LIFTING: Front telescopic cylinder, minimum 45° lifting angle, and cold-drawn, high-strength steel cylinder resistant to pressure at this angle.

ELECTRICAL SYSTEM: 7 x 24-volt lighting system compliant with ECE R48 regulation.

AXLE SET: The Axles 9 ton-12 ton can be preferred.

AXLE LIFTING: There is automatic lifting system sensible to load on the front axle.

TIRE/RIM: 6+1 tires and rims, size 385/65 R 22.5.

PUMP: Dual rotary gear pump with a capacity of 35-90 min./lt.

HOSES: R2 steel hoses resistant to a working pressure of 250 bar.

LANDING GEAR: Double-stage telescopic legs and gearboxes with a dynamic load capacity of 24 tons.

SIDE PROTECTION/GUARD: Fixed or foldable type compliant with ECE R73 regulation.

MUDGUARD: Full FRP mud protection on the wheel

PAINT: Sandblasting process in SA2.5 degree confirmed to ISO Standards is done before painting. Chemical cleaning are done after sandblasting process. It is done with epoxy primer and acrylic paint in paint cabin with oven. Zinc-Rich or Metallising process are done by customer request.

ACCESSORIES: Toolbox, water tank, tire bumper, fire extinguisher cabinet, necessary indicator signs, and optional accessories.



***Its M3 is available for customer request.**

VOLUME

Depending on customer preference, in the range of 18-32 m3.

BUFFER

Flexible buffer designed according to ECE R58 regulation. Optionally, a foldable buffer with pneumatic system.

OIL TANK

Specially designed, gasketed, and filtered oil tank.

FRONT PANEL - REAR DOOR

450 Brinell or 500 TUF hardness wear sheet/plate

CHASSIS

Imported S700MC or domestically reinforced S355JR chassis.

REAR COVER

It can be manufactured rear cover as hydraulic, mechanic and hydromechanic by customer request.

POOL MATERIAL

450 Brinell veya 500 TUF Sertliğinde HARDOX Sac Malzemenen

KING PIN

2-inch detachable flanged towing pin according to ECE R55 regulation.

REAR PALLET

For asphalt carriers, wear plate/covering with a hardness of 450 HB.

GROUND / SIDE WALLS

The imported wear sheet/plate with 5/4mm thickness, 450 Brinell or 500 TUF hardness.

TENT SYSTEM

It can be manufactured as hydraulics system, sliding system or automatic tent sytem.



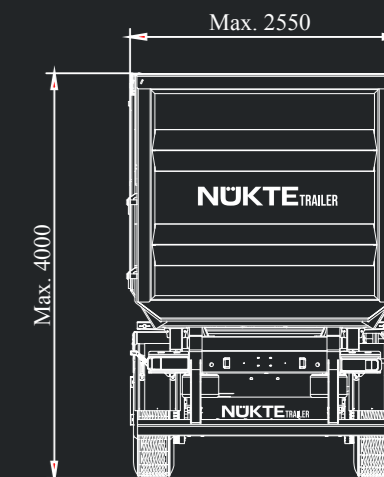
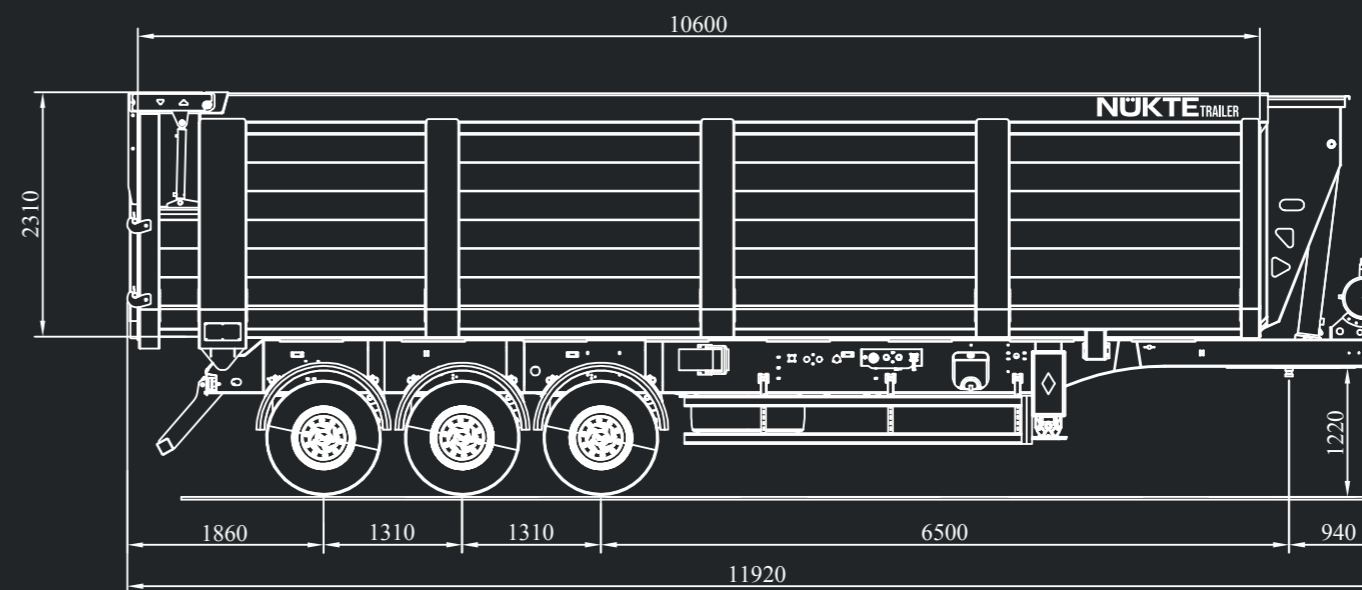

ACCORDION TRAILER

NÜKTE TRAILER

Türkiye / Konya - Factory

Büyükkayacık Mah. Konya 4. OSB 101 Cad. NO:24/1 Selçuklu/KONYA
Tel: 444 6 121 | E-mail: info@nuktetrailer.com | www.nuktetrailer.com

TÜRKİYE / İstanbul

Harbiye Mah. Abdi İpekçi Cad. Kamelya Apt. NO:9/4 Nişantaşı/Şişli/
İSTANBUL Tel: +90 212 225 02 01 | +90 538 021 10 42